

Dollhouse Parlor Sofa

Size: 5"L x 1 7/8"D x 4 1/8"H



We suggest that you print 2 copies of the pattern so as to have one for instructions and one to cut out.

What you'll need:

Wood: 3/16" balsa Sheet, 1/8" balsa sheet.

Basic tools & supplies, plus 2 small frozen orange juice cans, wide elastic bands or masking tape, embossed paper picture frame, wood tone paint, oaktag cardboard, 3/16"-thick cotton padding, 1/8 yard fabric, soutache braid, dye or felt tip pen, embroidery floss.

Suggested Finish: Walnut

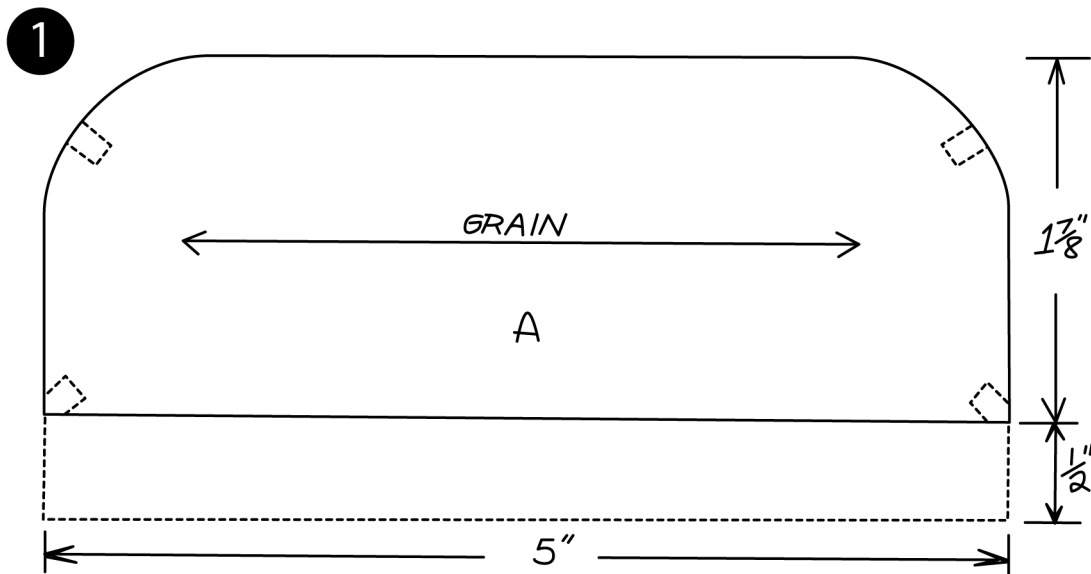

Piece A - Diagram 1

- Cut 1 piece 3/16" Balsa sheet (Solid Outline Only)
- Cut 1 piece from fabric (solid outline plus dotted outline)

2

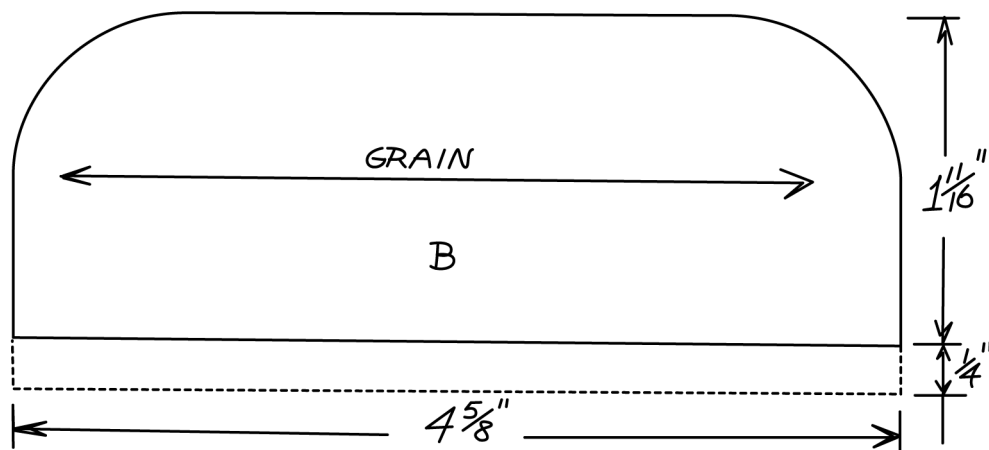

Piece B - Diagram 2

- Cut 2 pieces 1/8" Balsa wood (Solid Outline Only)
- Cut 2 pieces from Cotton padding (solid curved outline plus dotted outline).

Piece C - Diagram 3

- Cut 2 pieces from 1/8" Balsa wood (Solid Outline Only) Cut along vertical grain
- Cut 1 piece cardboard from pattern and reverse pattern (dotted curved outline to solid sloped outline)
- Cut two pieces cotton padding from pattern and reverse pattern (dotted curved outline to solid sloped outline).
- Cut 1 piece fabric from pattern and reverse pattern (dotted outline only).
- Cut 1 piece fabric from pattern and reverse pattern (solid outline only).

3

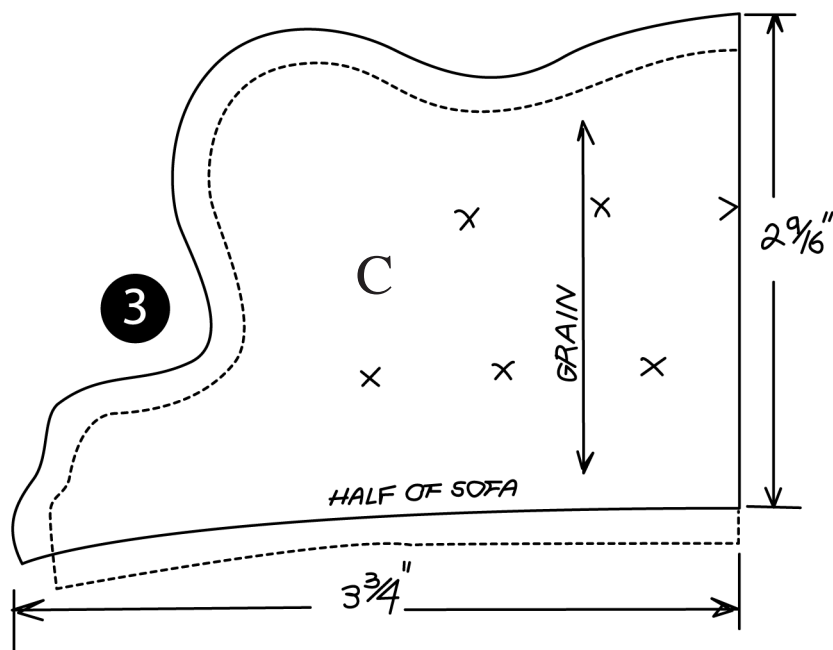

4

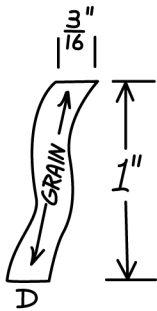

5

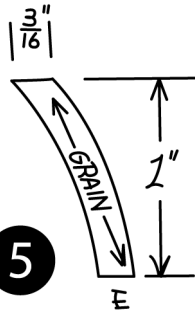

Piece D - Diagram 4

- Cut 2 pieces from 1/8" Balsa wood sheet.

Piece E - Diagram 5

- Cut 2 pieces from 1/8" Balsa wood sheet.

Cutting Wood

1. Cut pieces on lengthwise grain except pieces (C), which are cut on crosswise grain. Because the balsa sheet is only 6" wide, pieces (C), which form the sofa back have to be cut in two parts and glued together later.
2. The four rectangles on piece (A) are cut out later.
3. Glue together two 1/8" pieces (B) to form chair seat 1/4" thick or you may cut one piece for seat (B) out of 1/4" balsa sheet.

Cutting Cardboard, Cotton Padding and Fabric

1. Cut the eight pieces, cutting fabric crosswise. Since both halves of the sofa back (C) are identical, simply turn the (C) patterns to the reverse side to complete cutting of (C) pieces.

Sanding & Staining

1. Sand wood.
2. Round curved edges of sofa back pieces (C) very slightly. Soak one piece (C) in warm water for five minutes. Then bend (C) carefully around orange juice can with grain running vertically; start with curved armrest part of (C) and bend until you are within $\frac{3}{4}$ " of straight side edge; do not bend this edge. Hold wood in place with elastic bands used vertically or masking tape; don't let elastic bands indent the soft wet wood.
3. Let wood dry at room temperature or in a low oven for ten minutes. Repeat procedure for other piece (C), but be sure to bend wood in the opposite direction. When both pieces (C) are dry, glue straight side edges together to form one unit, the sofa back.
4. Stain wood.

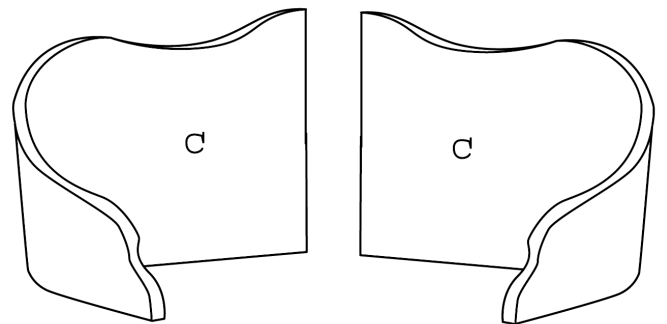
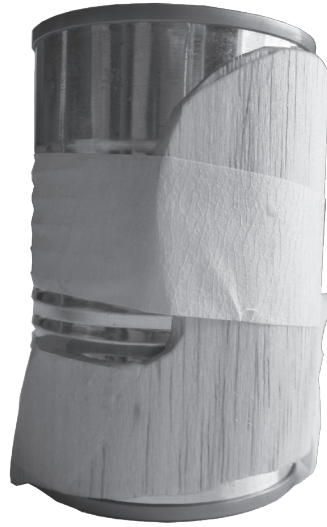

Assembling and Finishing Sofa Base, diagram 6

1. Carefully cut out four $\frac{1}{8}$ " x $\frac{3}{16}$ " rectangles from base (A), as indicated by broken lines in diagram 1. Glue legs (D) into cut-outs on straight edge of (A), with top edges of (D) flush with top surface of (A), and the long, $\frac{1}{8}$ " edges of (D) curving out at top and near bottom. Glue legs (E) into cut-outs on curved edge of (A) in the same manner; the long, $\frac{1}{8}$ " edges of (E) curve out.
2. Shellac assembly from step 1. Use steel wool to smooth legs very carefully.
3. Varnish assembly from step 1.

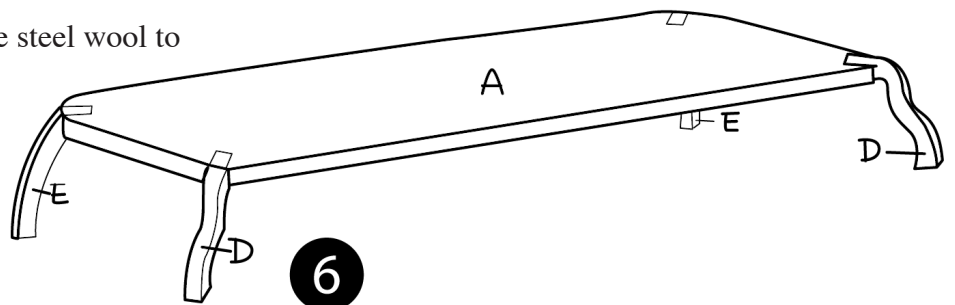

Finishing Sofa Back

1. Shellac all surfaces of sofa back (C).
2. Varnish all surfaces of sofa back (C).
3. Cut three corners of the embossed paper picture frame so they fit together nicely around top curved edge of sofa back (C); place one embossed paper corner at center of curved edge and two corners to each side of the center. Some piecing and trimming will be necessary; the entire top curved edge of (C) should have embossed paper covering it in varying widths. Glue paper in place on back surface of (C) using a few straight pins to hold paper until glue begins to set. Paint embossed paper with wood tone paint to match stain.
4. Glue fabric (C) that was cut from dotted line pattern as follows; Put small amount of glue along curved edge of fabric (not sloping bottom edge) and glue to outside of sofa back (C), beginning $3/16$ " down from top curved edge; smooth out fabric over curved arms as much as possible without breaking arms. Put glue along molded bottom edge of sofa back (C) and turn $3/16$ " of fabric (C) under bottom edge of sofa back and glue; be sure fabric is smooth and taut.
5. Dye soutache braid to match fabric. Glue braid to raw edges of fabric from step 4, following contour of curved edge; turn braid ends under bottom edge of sofa back and glue.

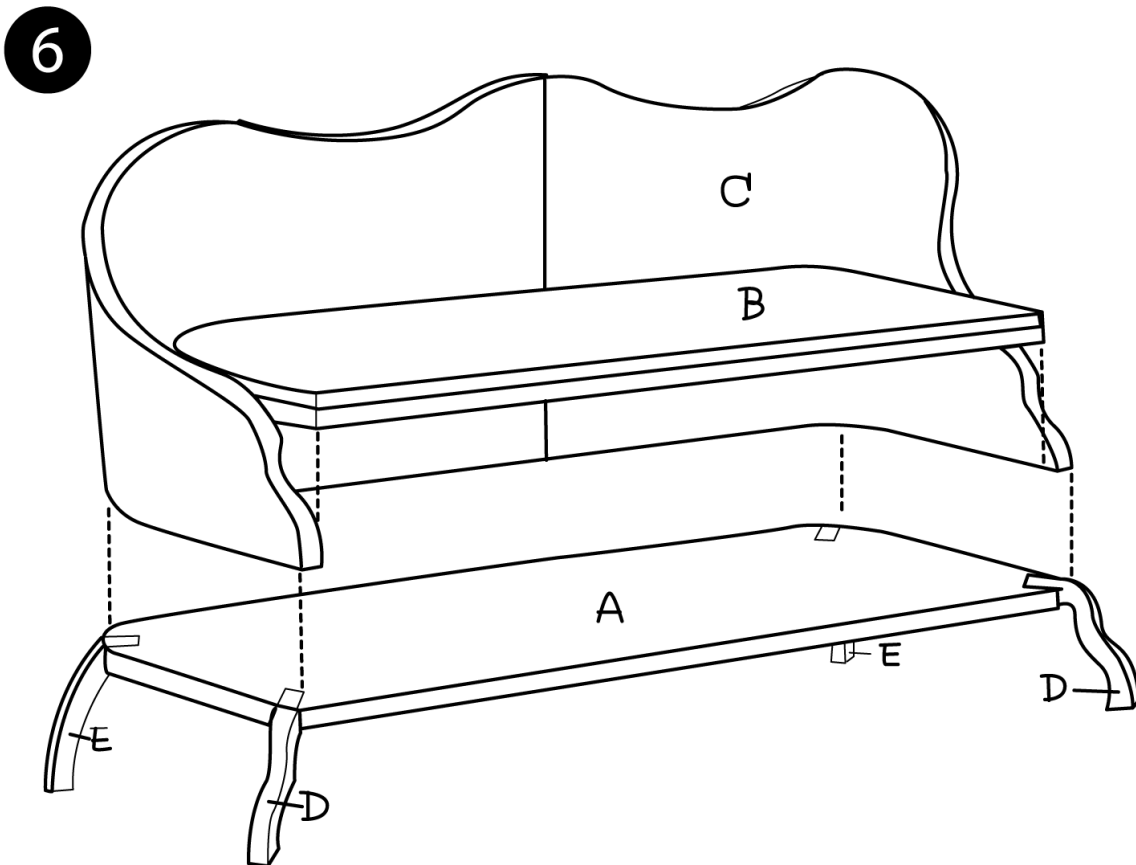

Assembling and Finishing Sofa

1. Glue sofa base assembly to sofa back assembly: Bottom edge of (C) is glued to curved edge of (A), and outside surface of (C) is flush with curved edge of (A). This may require some refitting and re-gluing.
2. For carving on base (A), glue 4 ¾" piece of embossed paper picture frame to straight edge of (A) between legs (D); some piecing may be necessary. Paint embossed paper with wood tone paint to match stain.
3. Fit oaktag (C) to inside surface of sofa back (C) so a 3/16" curved edge of back (C) shows evenly; you may have to trim oaktag. With oaktag on work surface, put small amount of glue along wrong side of sloped bottom edge of oaktag and place two pieces of cotton padding (C) on top. Put small amount of glue along wrong side of sloped bottom edge of fabric (C)—cut from solid line pattern—and put fabric on top padding right side up. You may have to secure these bottom edges further with needle and thread. Turn assembly over so oaktag is on top. Put glue along curved edge of oaktag and glue the 3/16" curved edge of fabric to back of oaktag. To facilitate gluing, make tiny cuttings on edges of seam allowance, especially at narrow curved portions of oaktag. Glue fabric as smoothly and tautly as possible, because when oaktag assembly is put in place, it will be curved.
4. Mark fabric (C) with straight pins for placement of French embroidery knots made to resemble the buttons used on heavily tufted furniture. Embroidery floss should match fabric. To make one French Knot: Knot one end of embroidery floss and stitch from oaktag back to front of fabric, Pulling needle and tread completely through;

wind floss around tip of needle twice and return needle from fabric front to oaktag back as near as possible to the same hole. Repeat the procedure for the rest of French knots.

5. Glue entire oaktag assembly to inside surface of sofa back (C), making sure a 3/16" curved edge of (C) shows evenly.
6. Place both pieces of cotton padding (B) on top surface of sofa seat (B) so padding overlaps straight edge of seat. Place fabric (A) right side up on top of padding so curved edge of fabric overlaps 3/16" along curved edge of padding and straight edge of fabric overlaps 1/2" along straight edge of seat. Glue fabric to bottom surface of seat 1/4" in from straight front edge; glue curved edge of fabric to curved edge of seat, making sure fabric is smooth and taut; turn in and fold fabric at two corners and glue to side edges of seat. Glue seat assembly to top surface of base (A) and to bottom edge of sofa back assembly so seat fits snugly.

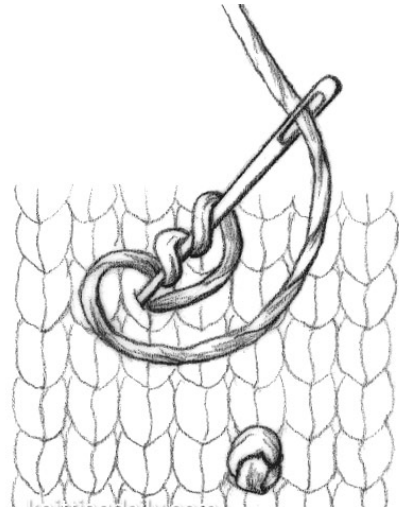

Variation:

VICTORIAN SOFA

A typical Victorian sofa may be made with the same directions by eliminating the embossed paper carving.